



360a Top Bottom Split Conveyor

The CTM split conveyor labeling system consists of two conveyors with a single motor to maintain speed



Setting Global Standards
One Customer at a Time

www.ctmlabelingsystems.com

360a Top Bottom Split Conveyor

Features:

The CTM split conveyor labeling system consists of two, 3ft. long conveyors positioned in-line driven with a single variable speed DC drive motor to maintain a common speed across a short transfer gap. This design allows not only top labeling with any of CTM's fine line of advanced 360a applicators or 3600a printer-applicators, but the gap allows the use of its merge applicator for wipe on labeling to the bottoms of various products such as trays and clamshells.

The conveyors use 12" wide high friction white belting material for product traction and gap transfer, while a "v" section on the underside mates with a "v" grooved stainless steel bedplate for positive belt tracking; side frames are also stainless steel.

Main frame and labeler mountings are "Steel-It" painted carbon steel with stainless steel as an Option.

Bottom labeling for print and apply uses the CTM 360a merge labeler with integrated loose loop design.

Standard speed is up to 100 ft./minute with option to 120 ft./min.

A NEMA 4 enclosure mounted to the conveyor side frame includes an OSHA lock-out.

An Optional encoder with splitter cable is used for speed following of both labelers.

Standard Features:

- Nema 4 main enclosure
- OSHA Lock-out
- Heavy duty welded tubular steel main frame
- "Steel-It" paint
- Heavy duty motor and gearbox

Electrical:

108-132 Volts AC
(208V, 220V optional)

10-20 Amps,
50/60 Hertz,
Single Phase

Environmental:

Operating: 40° F to 105° F
(5° C to 40° C)

Storage: -4° F to 105° F
(-20° C to 40° C)

Optional Features:

Stainless steel frame

Encoder speed following with splitter cable assembly for both labelers

Stack light(s)

Label on product scanning and eject

Pneumatic – required with certain features

System dimensions:

Varies, approx. 75" height, to 72" long standard, to 96" long custom

Weight:

Approx. 1200 lbs.

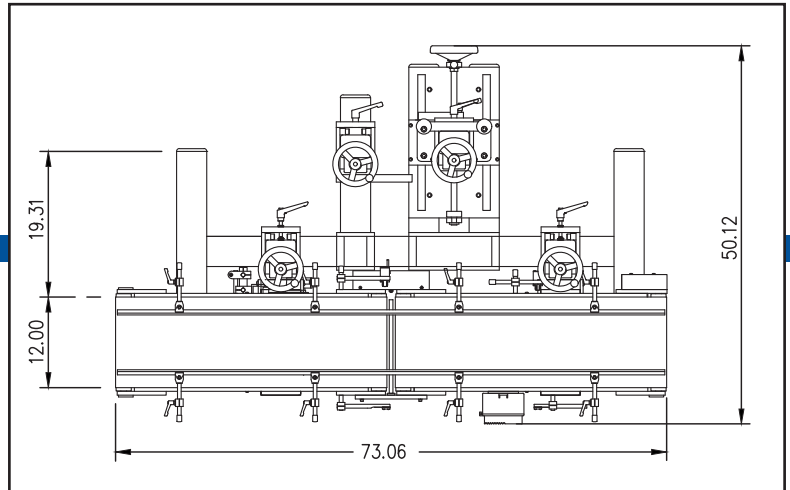
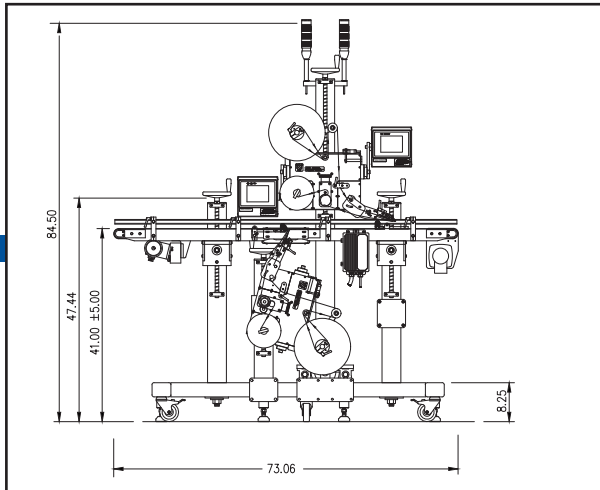
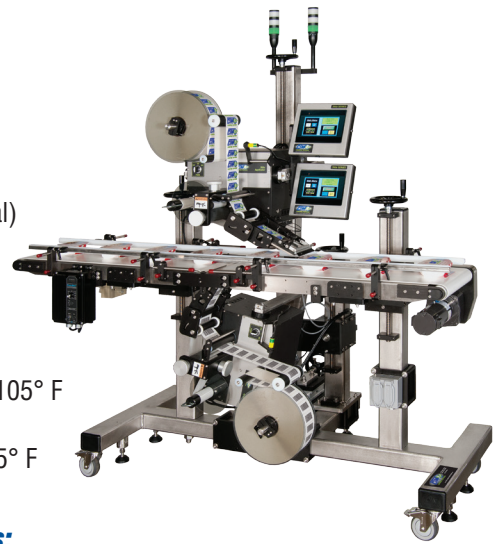

Distributed By:

NORTHFIELD CORPORATION
1870 COMMERCE DRIVE
DE PERE WI 54115
920-983-8122
SALES@NORTHFIELD CORP.COM



1318 Quaker Circle
P.O. Box 589
Salem, Ohio 44460
(330) 332-1800

