

Front and Back Labeling System



Innovations in Labeling
www.ctmlabelingsystems.com

Front and Back Labeling System

Features:

The CTM Front and Back Labeling System is a fully automatic, high quality, competitively priced labeling system designed around the customer's exact labeling need. The unit is an open frame design that can accommodate any of CTM's fine line of advanced 360a "touch screen" applicators or 3600PA print and apply units for merge, air blow and tamp blow label attachments.

The short pitch, high performance acetal chain allows low friction and dry running on the hard anodized, Teflon impregnated extruded aluminum sideframes. Continuous t-slots provide easy component mounting and adjustability, and all labeler mountings include ball bushing traverse slides as standard. The top holddown belt is servo motor driven to precisely follow the conveyor velocity throughout its full range up to 90 ft. per minute as standard, and to 120 ft. per minute optional.

Feedscrew, belt aligner and meter wheel spacing and orienting devices develop the demanding accuracies required by challenging applications. A wrap belt assembly can be included for wrap around applications when required on the same process.

Standard Features:

- Nema 4 main enclosure
- OSHA Lock-out
- Slanted console operator station
- Heavy duty welded tubular steel main frame
- "Steel-It" paint
- Heavy duty motor and gearbox
- GE Fanuc and/or Allen-Bradley controls

Electrical:

- 108-132 Volts AC,
- 10-20 Amps
- 50/60 Hertz,
- Single Phase
- 208V, 220V,
- 440V optional

Optional

Features:

- Stainless steel frame, HMI operator touch screen
- Encoder speed following for labelers, Stack light(s)
- Label on product scanning and eject
- Pneumatic – required with certain features
- **Consult manufacturer for other options

System dimensions:

Varies, approx. 75" height, 96" width, to 144" long

Weight:

Approx. 1200 lbs

Environmental:

- Operating: 40° F to 105° F (5° C to 40° C)
- Storage: -4° F to 105° F (-20° C to 40° C)

Conveyor Variations:

- 6' to 12' long
- 2.3" to 12" wide

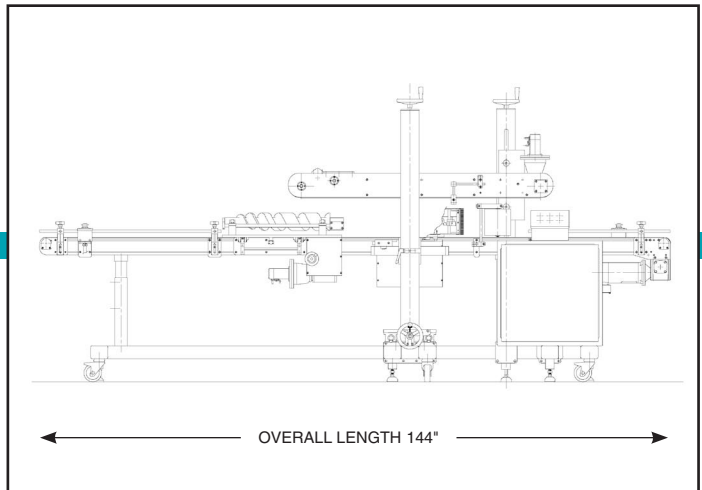
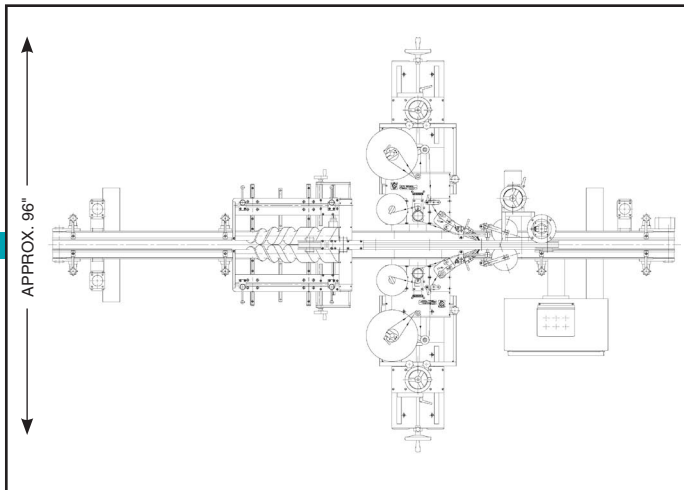

NOTE: System dimensions and options shown vary by application.

Distributed By:



1318 Quaker Circle
P.O. Box 589
Salem, Ohio 44460
(330) 332-1800

www.ctmlabelingsystems.com

