



NORTHFIELD CORPORATION

O.E.M. OF NORTHFIELD CONTINUOUS FEED COUPON INSERTERS

Beverage Can and Bottle Labeling System



Featuring:

- Complete parts inventory on all equipment
- Service technicians available 24 hours a day, 7 days a week.
- Over 30 years experience worldwide with numerous companies, both large and small
- In-field consultation

Dedicated to efficient installation, service, and sales of pressure sensitive labelers, coupon inserting equipment, and neck hanger/ElastiTag® applicators which ensures that the correct equipment is used for every job, every time.

System Specification:

- up to 100+ cans per minute
- 120VAC power, 15 amp circuit
- Variable speed AC motors for wrap station, spacing wheel, and conveyor
- Powered spacing wheel
- 6" tall x 18" long wrap station for 360° application
- 3" wide x 6' long mattop conveyor
- Anodized aluminum and powder coated steel
- Optional stainless steel and washdown construction available
- Mounted on 4" locking casters for easy mobility
- Labeler mount with easy vertical and horizontal screw adjustment
- Tilt leveling block to keep label applicator level, improves label accuracy on can/bottle
- Conveyor height can be customized to match your filler

360A merge label applicator specifications:

- 6" color touch screen HMI
- Stepper motor with 1,500 IPM max dispense speed
- 5" and 7.5" label width configurations
- 12" unwind with 3" cores —optional 16" upgrade
- Label placement +/- 1/32" at peel plate
- Options:
 - ◆ Lion precision clear label sensor
 - ◆ Collapsible rewind mandrel for poly web
 - ◆ 3 Color light alarm stack
 - ◆ Web break sensor
 - ◆ Low label sensor
 - ◆ Encoder for speed following
 - ◆ Code date options available
 - ◆ Capture station for front/back labeling

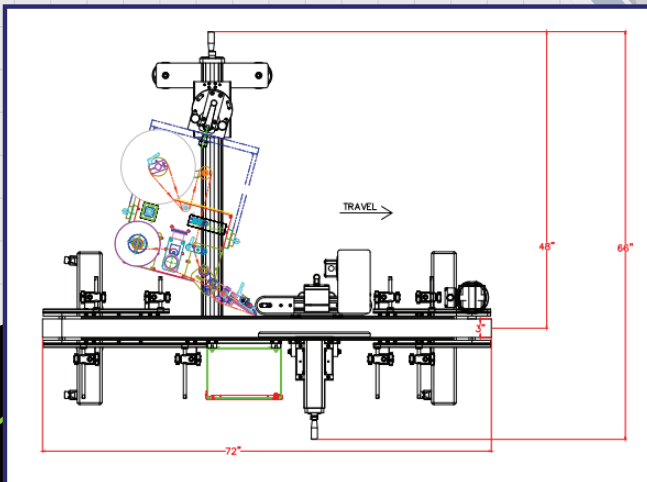

NORTHFIELD CORPORATION

1870 Commerce Drive • De Pere, WI 54115
920-983-8122 • Fax 920-983-8124
sales@northfieldcorp.com
www.northfieldcorp.com