

# NORTHFIELD



---

NORTHFIELD CORPORATION

1870 COMMERCE DRIVE

DE PERE, WI 54115

[WWW.NORTHFIELDCORP.COM](http://WWW.NORTHFIELDCORP.COM)

MANUFACTURER:

**NORTHFIELD CORPORATION**

1870 COMMERCE DR.

DE PERE, WI 54115

UNITED STATES

MODEL:

**NORTHFIELD NCLS**

SPECIFICATIONS:

*VOLTAGE:* 120VAC

*FREQUENCY:* 50/60Hz

*CURRENT:* 5 AMP

*AIR:* 80 PSI (for some models)

YEAR OF MANUFACTURE:

YEAR: (2026)

FOR PARTS, SERVICE, AND  
TECHNICAL ASSISTANCE  
CALL:

**NORTHFIELD CORP.**  
**1870 COMMERCE DR.**  
**DE PERE, WI 54115**  
**920-983-8122 PHONE**  
**920-983-8124 FAX**  
**[WWW.NORTHFIELDCORP.COM](http://WWW.NORTHFIELDCORP.COM)**

# TABLE OF CONTENTS

## **SECTION # 1**

MANUAL OVERVIEW .....	5
MACHINE OVERVIEW .....	6
WARNINGS AND CAUTIONS .....	7
SYMBOLS AND THEIR DEFINITION .....	8
SAFETY PROCEDURES FOR LOCK OUT .....	9
ILLUSTRATIONS .....	10

## **SECTION # 2**

MACHINE SPECIFICATIONS .....	11
PARTS AND FUNCTIONS .....	12
DEFINITIONS OF PARTS AND OPTIONS .....	12

## **SECTION # 3**

CONTROL PANEL AND OPERATOR INTERFACE .....	14
LABELER SETTINGS.....	17

## **SECTION # 4**

SET-UP PROCEDURES .....	27
THREADING LABELS .....	28
LABEL SENSOR SETUP .....	30
CLEANING PROCEDURES .....	30

## SECTION 1

### **Manual Overview**

In this manual Northfield Corporation will give you a comprehensive outlook and reference to help you set-up, maintain, and run the *Northfield NCLS LABELER*. We at Northfield, have trained competent technicians to answer any questions that may arise, or anything that is not covered in this manual. You can E-Mail, call, or fax us at northfieldcorp.com, (920) 983-8122 phone, (920) 983-8124 fax.

Our regular business hours are Monday thru Friday 7:30 AM to 4:00 PM central time zone, with 24 hour emergency service. (Available upon request)

## **Machine Overview**

*The Northfield NCLS Labeler.*

## Warnings and Cautions



**REMEMBER: AT ANYTIME, THERE IS A RISK THAT YOU MAY INJURE YOURSELF, OTHERS, OR CAUSE SERIOUS MACHINE DAMAGE. PLEASE USE CAUTION AND COMMON SAFETY PRACTICES WHEN WORKING ON THIS OR ANY MACHINE.**

- DO NOT OPERATE THE LABELER WITHOUT THE PROPER TRAINING AND INSTRUCTION.
- KEEP HANDS CLEAR OF THE BELTS AT ALL TIMES. SERIOUS INJURY COULD RESULT IF THE LABELER CYCLES. CYCLING IS CONTROLLED BY OUTSIDE SIGNALS THAT COULD START A CYCLE AT ANY TIME.
- DO NOT ATTEMPT TO CLEAR A JAM WITHOUT SHUTTING DOWN THE POWER.
- DO NOT OPERATE THE LABELER WITHOUT PROTECTIVE GUARDS AND COVERS IN PLACE.
- DO NOT ATTEMPT TO WASH DOWN THE CONTROLLER OR THE LABELER; THEY MUST BE REMOVED OR COVERED DURING WASH DOWN.
- ONLY QUALIFIED PERSONNEL SHOULD SERVICE THE LABELER. SERIOUS PERSONAL INJURY OR EQUIPMENT DAMAGE COULD RESULT.
- WHEN CONNECTING THE CONTROLLER TO THE HEAD CONNECTIONS, DO NOT HAVE ANY POWER TURNED ON OR HOOKED UP.
- IF ANY COMPONENTS OF THE MACHINE WEIGHS MORE THAN 39lbs (18kg) IT MUST BE LIFTED BY TWO PEOPLE.
- YOU WILL FIND THESE WARNING LABELS LOCATED ON THE LABELER, DON'T REMOVE COVERS OR GUARDS.



FINGER PINCH



HIGH VOLTAGE



HAND PINCH

## SYMBOLS AND THEIR DEFINITIONS

In this section, all the symbols that are used on the NCLS labeler will be displayed and defined.



= **ON** This is used by turning the disconnect on the side of the panel. Turning the disconnect to this position.



= **OFF** This is used by turning the disconnect on the side of the panel.



= **FEED** This symbol is used on the push button that will cycle the labeler once. It can also feed by pressing the FEED LABEL button on the main screen of the Display. (For CYCLE definition go to page #15)



= **PRODUCT SENSOR** This symbol is used for the product sensor plug. (For product sensor definition go to page #17)

## **Safety Procedures for Lock out Tag out**

### **LOCK OUT TAG OUT PROCEDURE**

Lock out for the electrical is completed by putting a lock on the disconnect on the side of the box, that way the electrical can't be powered up.

Lock out for the pneumatic power supply is completed by removing the supply hose from the labeler.

\* REMEMBER TO FOLLOW YOUR COMPANIES LOCK OUT TAG OUT PROCEDURES

## Illustrations

ILLUSTRATIONS SHOULD BE USED DURING AND AFTER TRAINING.  
ILLUSTRATIONS MAY ALSO BE USED AS A REFERENCE GUIDE.

Pictures, drawings, and diagrams are inserted in the manual for explanation and illustration of machine and controller workings. These illustrations will be useful in showing you where specific items are placed on the machine, as well as specific places to use caution when repairing, performing maintenance, or operating the *Northfield CLS labeler*.

## **SECTION 2**

### ***Machine specifications***

POWER REQUIREMENTS – 115 VAC 50/60Hz  
AIR REQUIREMENTS - 80PSI (551KPA)

## ***Parts and Functions***

### ❖ **Overview**

In this section, the manual will give a breakdown of how the *Northfield NCLS labeler* works. In this section you should have the knowledge to assemble various parts of the *Northfield NCLS labeler*.

### ❖ **Basic Principles of Operation**

The *Northfield NCLS labeler* is a very simple machine in many aspects. The *Northfield NCLS labeler* can handle labels in roll form. The illustration will show the basic parts and functions of the labeler.

## ***NORTHFIELD NCLS LABELER DEFINITIONS OF PARTS AND OPTIONS***

### **Overview**

In the basic parts list, there are all of the parts needed to familiarize yourself with the *Northfield NCLS labeler*. The explanations given will help you locate and identify the parts. If you can identify the parts, set up and operation of the machine it will be easier for you to accomplish.

**CYCLE BUTTON** There are two cycle buttons located on the labeler. One is on the bottom left side of the NCLS. The other one is located on the main screen of the display. These buttons will cycle one label.

**DRIVE BELTS** Located inside of the labeler and are used to drive the roller and rewind.

**DRIVE ROLLER** Roller that drives the web/liner through the labeler.

**NIP ROLLER** the nip roller presses the web/liner into the drive roller.

**DISPLAY** The interface between the machine and the human running it.

**TENSION BRUSH** A brush that is on the labeler that keeps the tension on the web/liner.

**LABEL SENSOR** A sensor that senses if there is a label and senses the gap so it knows when to stop the label.

**FUSES** Located in the control panel, the fuses help to protect the electrical components from damage. (Power surges or shorts in the circuits) There are two fuses located in the control panel (Fuse #1 is a 5 amp slow blow fuse, and is used for the 110 VAC incoming power. Fuse #2 is a 1 amp fast blow fuse, and is used for protecting 24 volts power.

**MOTOR** Located inside of the labeler, under the cover. It is used to drive the drive rollers.

**NIP ROLLER** The spring-loaded nip roller provides positive pressure to the label liner that passes between the drive and nip roller assemblies.

**PEEL PLATE** The peel plate is located at the end of the applicator nose. When the label liner is pulled around the peel plate, the label separates from the liner.

**POWER SUPPLY** Located in the control panel, this device supplies the 24vdc to the components in the control panel which requires 24vdc.

**PRODUCT SENSOR** This sensor detects the product and gives a signal to the machine, letting it know when it's time to apply the label.

**WEB SPEED** The Web Speed is the speed the web/ label liner is being pulled through the labeler.

**LABEL STOP** The label stop is the position that the label stops after each move. The stop should be at the edge of the peel plate.

**LABEL PLACEMENT** The time from when the product sensor sees the product from when the label is placed on the product.

**UNWIND** Is an option when using the labeler using labels in a roll format.

## Section3

### Control Panel and Operator Interface

#### Overview

In this section you will familiarize yourself with the control panel, and how to navigate through the operator interface. There are illustrations to help you set up the interface. This section is designed to minimize downtime, and increase your productivity by giving you detailed instruction on this important feature of the *Northfield NCLS labeler*.

#### Operator Control Panel

The control panel is designed to be self-contained. There are some connections you will have to make on the side of the panel of the labeler for operation. Every connection has its own unique connector so there will be no confusion.



**REMEMBER: AT ANYTIME THERE IS STILL A RISK THAT YOU MAY INJURE YOURSELF, OTHERS, OR CAUSE SERIOUS MACHINE DAMAGE. PLEASE USE CAUTION AND COMMON SAFETY PRACTICES WHEN WORKING ON THIS OR ANY MACHINE.**

**WHEN CONNECTING THE CONTROLLER TO THE HEAD,DO NOT HAVE ANY POWER HOOKED UP.**

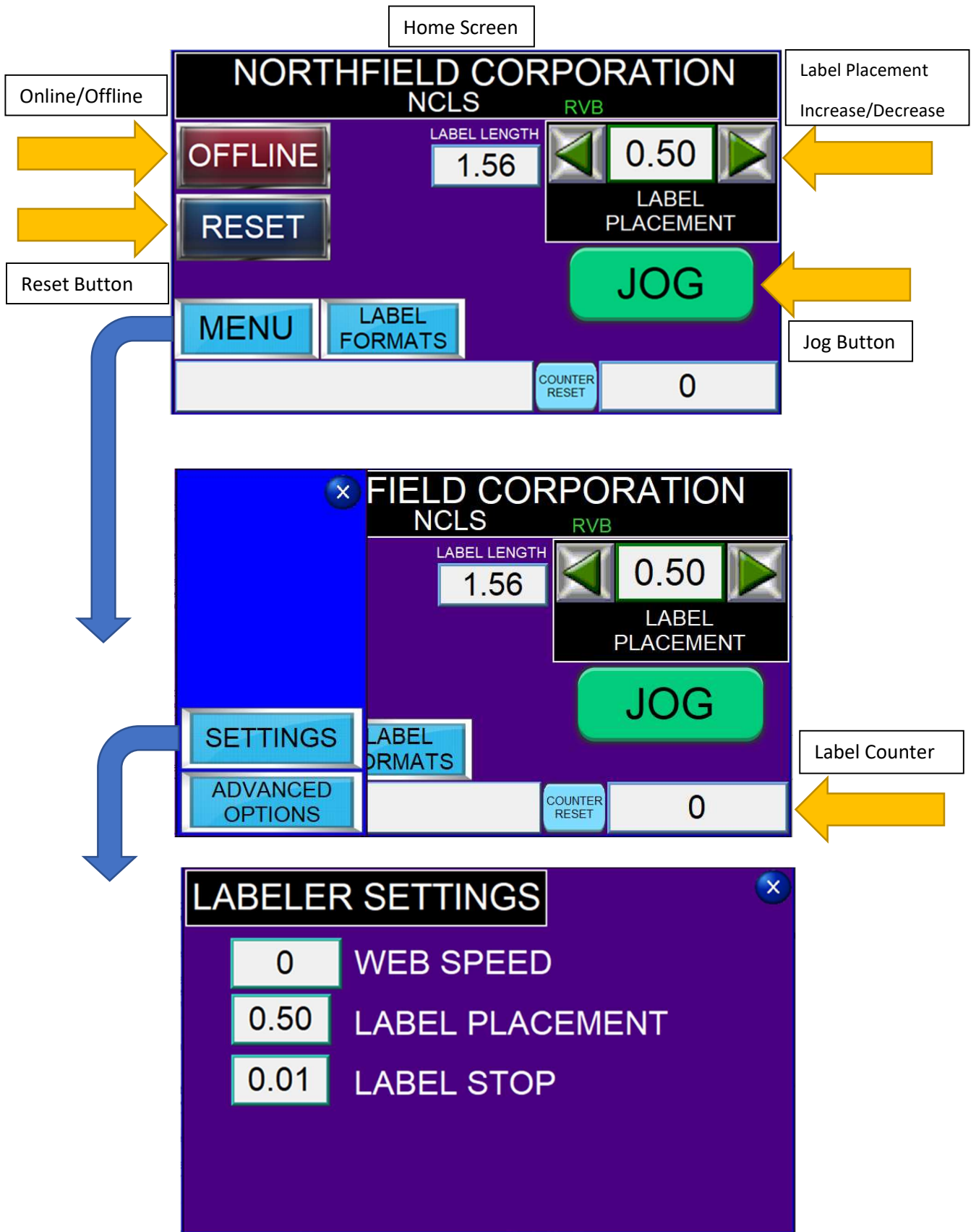

# LABELER SETTINGS

**WEB SPEED** The speed web/liner is pulled through the labeler

**LABEL PLACEMENT** The time from when the product sensor sees the product from when the label is placed on the product.

**LABEL STOP** The position that the label stops after each move. The stop should be at the edge of the peel plate.

These settings can be changed by tapping on the menu button on the main screen of the display.

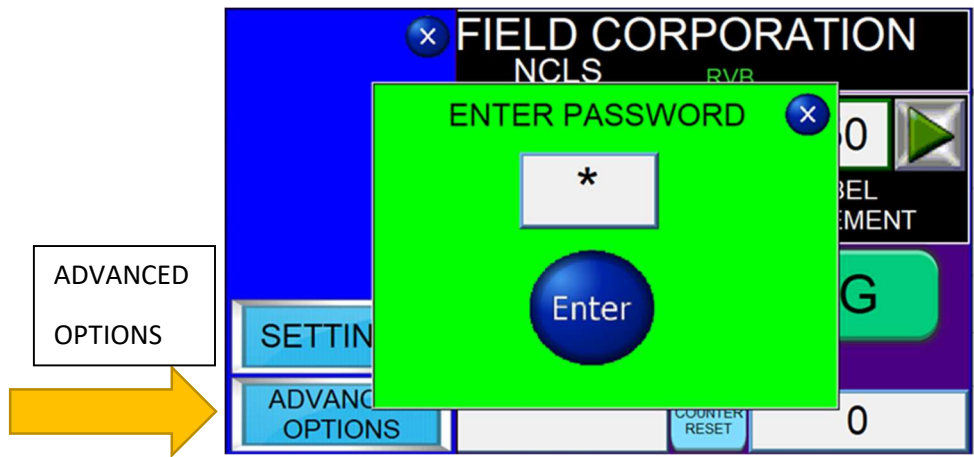

Advanced Options button will prompt a password screen. Password 1870.

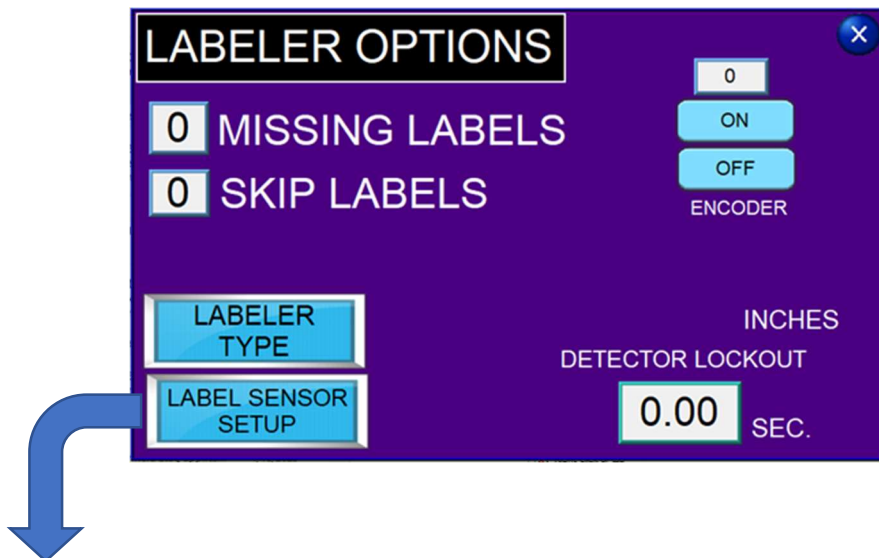

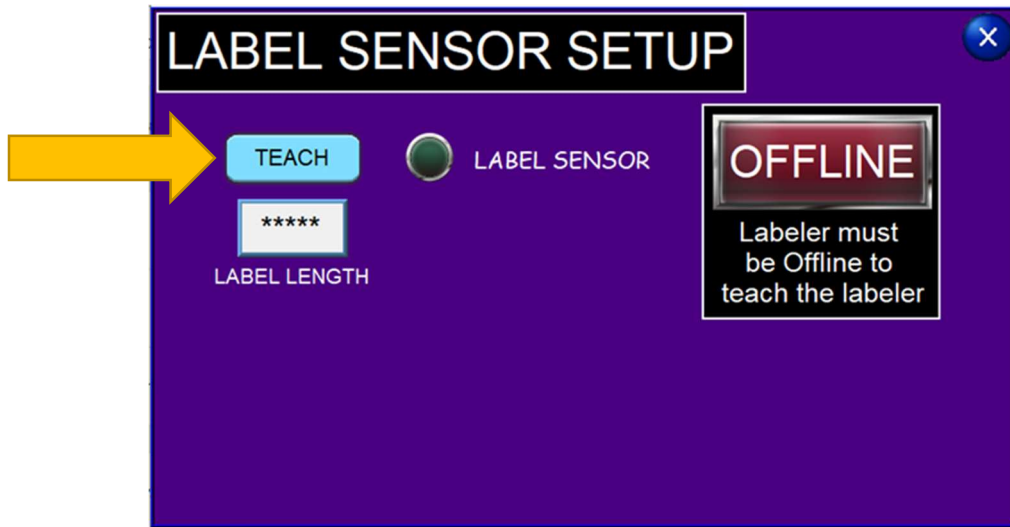

The Teach Button will cycle label through the label and teach the label sensor and measure the label length. The Labeler must be Offline to Teach Label.

**(Teach is disabled when using a clear label sensor)**

The LRD6300 has both Gap Set and Gain adjustments.

The LRD6300 Single-Ended Capacitive Label Sensor has an automatic setup and manual adjustments:

1. Remove a label from the liner
2. Place liner only in the sensor
3. Press and hold the "G" button for one second until lights begin to move back and forth, then release the button
4. Setup complete
5. Verify that a light is on in the LABEL section during a label and in the GAP section during a gap. The manual UP and DOWN arrows can be used to adjust the light bar should it be required.



If the light bar is not moving more than three lights between label and gap, turn on the High Gain setting and repeat the steps above.

**WEBBING DIAGRAMS**

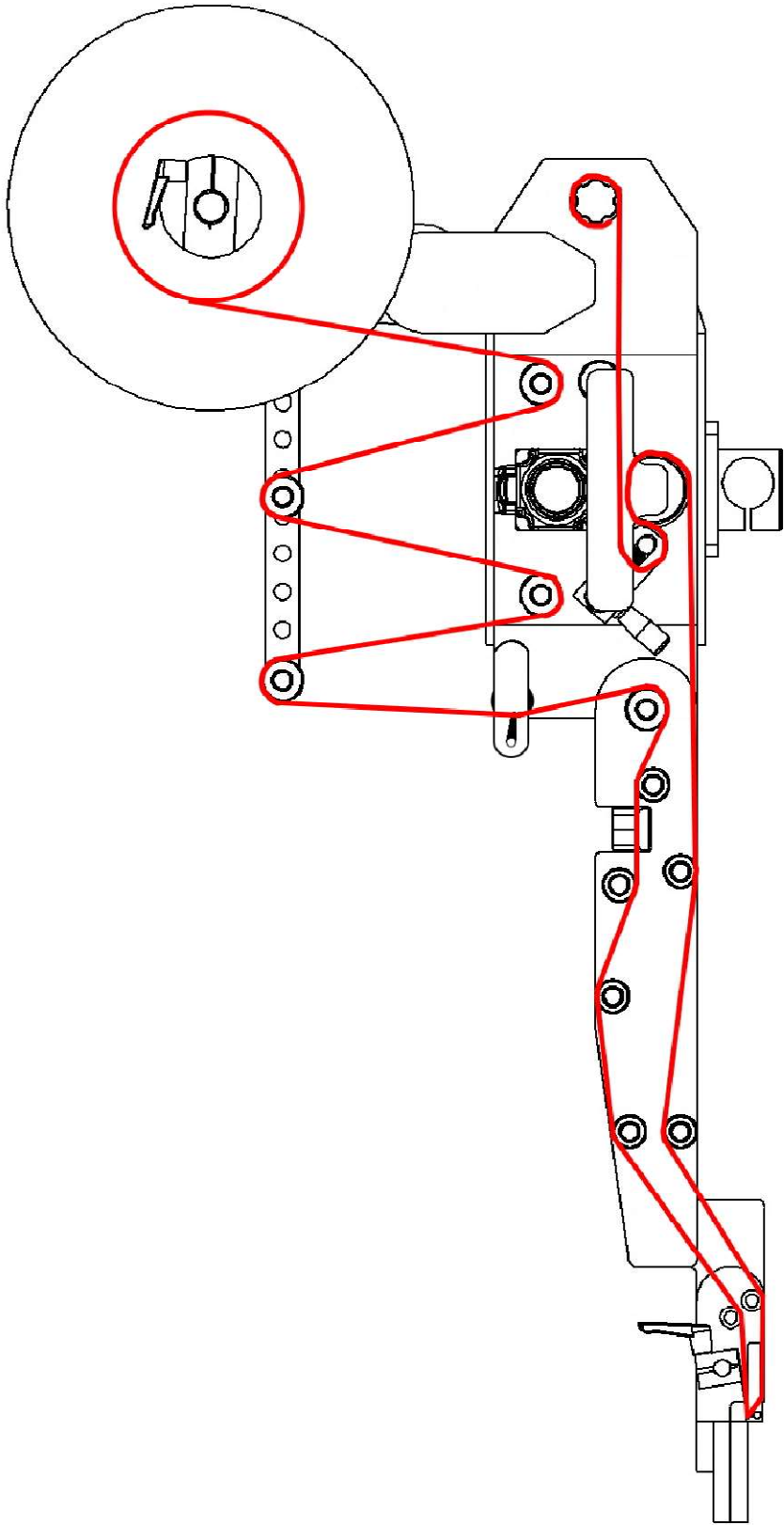

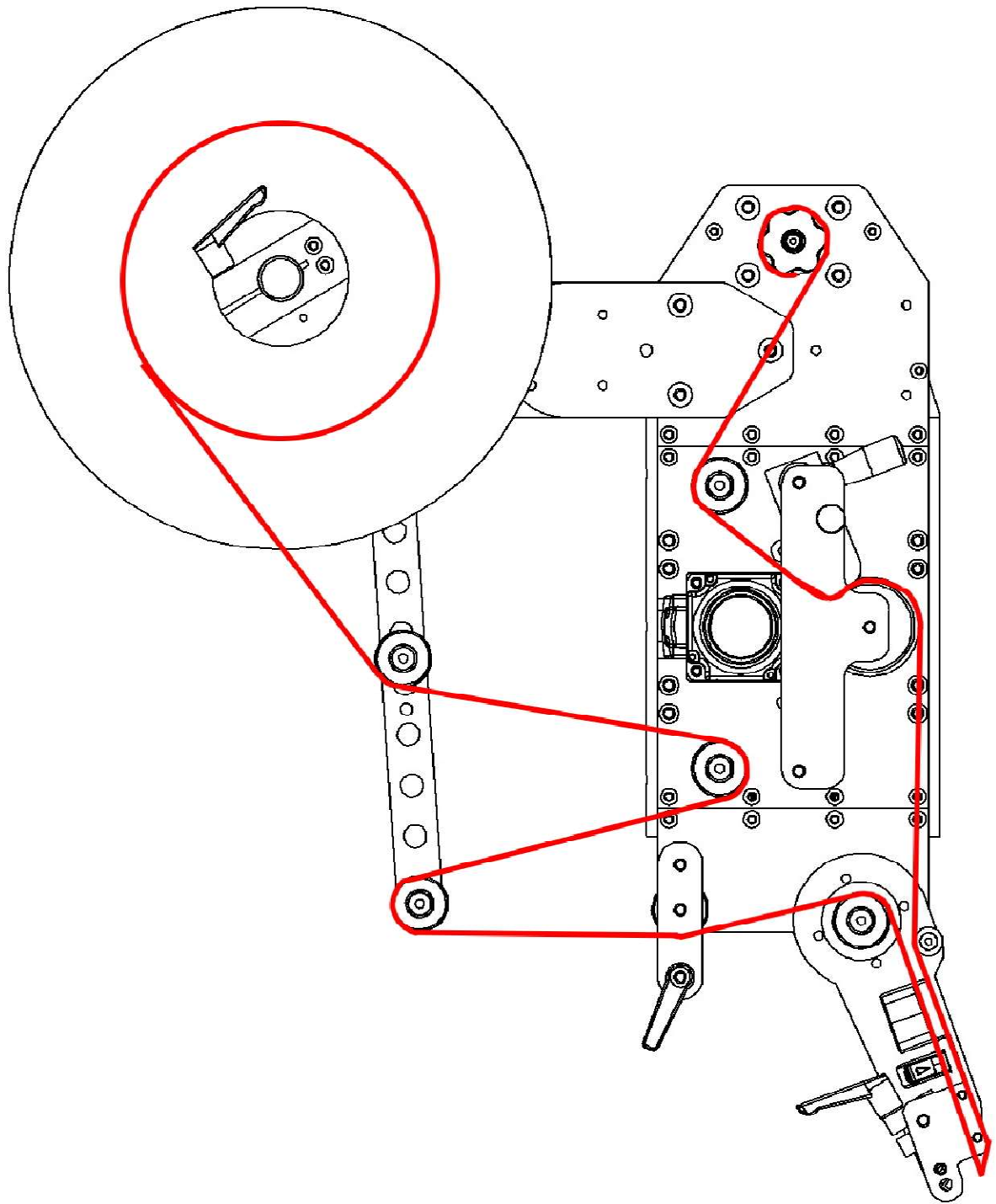

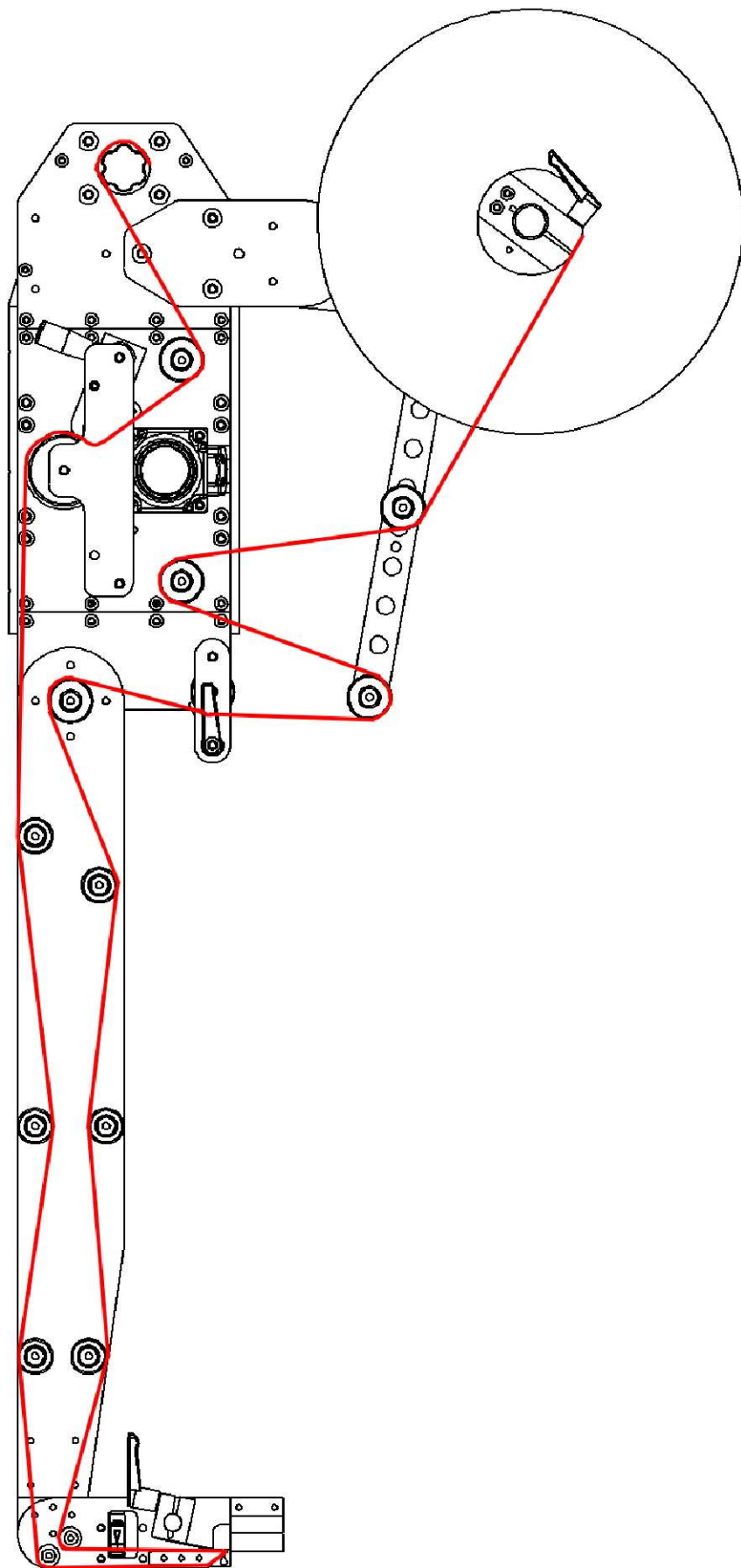

## Section 4

### Set-up Procedures

#### Overview

This section will help you set-up the *Northfield NCLS labeler* after it has been shipped to your location. It is a good idea to visually inspect the *Northfield NCLS labeler* for any damage before setting it up. If any damage occurred during the shipping process, notify your supervisor immediately.

#### Bracketry set-up

Mount the labeler head in the location that labeling will take place using the supplied brackets or stand. The label position is needed when mounting the labeler for correct operation. When machines are sold without a stand, the stability of the machine is then the responsibility of the end user when incorporating it within their system. A pre-installation survey is recommended for new applications to determine location, brackets, and any options needed to ensure a successful promotion. Other things taken into consideration are; product spacing and speed, orientation, linear speed, and convenience for the operators. For a survey please contact Northfield Corporation.

#### Machine Set-up

Machine set-up is a very important part of any project.

- ✓ After the machine is inspected for shipping damage you should mount the labeler head on the brackets provided
- ✓ After the head is secure you can start the set-up procedure.
- ✓ Mount the controller in a place where it can be easily accessed
- ✓ Connect the Harting connections from the control panel to the labeler head
- ✓ Connect the sensor cable from the control panel to the sensor on the labeler

## LABEL SENSOR SET-UP

Steps to set up the label sensor.

1. Press and hold yellow button on the sensor, the LED will blink green
2. Advance label to the most transparent spot of the label, and press the yellow button
3. Advance the web to the gap, and press the yellow button again
4. The amber light should be on when the label is present, and the amber light will be off when the gap is present

## CLEANING PROCEDURES

### Cleaning

The *Northfield NCLS Labeler* must not be sprayed down. If the labeler is mounted on a piece of equipment that needs to be washed down, the labeler must be removed or covered in plastic and sealed so that no water touches the labeler. **The labeler is not watertight!**

If the labeler needs to be cleaned, you must wipe it down with a cleaning solution. If the labeler is running in a food environment, the labeler must be cleaned with a disinfectant. The black rubber roller should only be cleaned with soap and warm water. If the wrong solution is used on the black rubber rollers, it could break down the rubber.